



# Airovent WHV-8/WHV-8/14

## Continuous low cost ventilation for the whole house.

**Airovent WHV-8 / WHV-8/14** designed to provide extraction levels that comply with the latest **Building Regulations 2010 (PART F)**.

With three speed settings for low, medium and high speed extraction **WHV-8** and **WHV-8/14** provide quiet and continuous ventilation.

Model **WHV-8/14 R** comes equipped with a remote control and built-in humidity sensor for effective use.

### Key Features

- 2 years warranty.
- Extracts air from multiple rooms simultaneously.
- SAP Appendix Q Eligible.

### Application

For use in both new and refurbished houses, flats, apartments and sheltered accommodation.

### Airovent WHV-8

**Part No: 72649301**

### Airovent WHV-8/14

**Part No: 72649401**

**Airovent WHV-8/14 R** (with remote control and humidity sensor)

**Part No: 72649501**

By continuously extracting stale, moist air from the whole house, the Airovent ventilation system creates a healthier indoor environment. This helps to alleviate the problems of dampness and condensation, so benefiting both the fabric of the building and occupant health.

### Features:

- Designed for continuous operation.
- Simultaneous extraction from multiple rooms.
- Helps reduce condensation problems.
- Low noise, long life motors.
- Four inputs for duct connections.
- Optional versions (WHV 8/14 R) with wireless remote control and built-in humidity sensor.
- Optional accessories for humidity and timer control.
- Ducting, grilles and flow control valves available.
- Low specific fan power.

*An excellent option for whole house ventilation; conveniently located in a loft or cupboard, you won't even notice it's there...*

### Airovent WHV-8 / WHV-8/14



For more information please visit [airflow.com](http://airflow.com) or email us at [info@airflow.co.uk](mailto:info@airflow.co.uk) or call **01494 560800**

**SAP Appendix Q Testing Results**  
**Central exhaust ventilation system packages used in a single dwelling**

<b>Brand Name</b>		Airflow
<b>Model</b>		WHV-8
<b>Model Qualifier (if applicable)</b>		
<b>Current Manufacturer and Contact Details</b>	<b>Name</b>	Airflow Developments Ltd
	<b>Address</b>	Lancaster Road Cressex Business Park High Wycombe HP12 3QP
	<b>Telephone</b>	01494 525252
	<b>Website</b>	www.airflow.co.uk
<b>Original Manufacturer (if different)</b>		
<b>First Year of Manufacture</b>		2008
<b>Last Year of Manufacture</b>		
<b>Testing Body</b>		BRE
<b>Date of test</b>		17/06/08
<b>Serial Number of Product Tested</b>		WHV-80508
<b>MEV to outside grille duct type and size</b>		150 & 125 mm diameter rigid plastic & 200 mm rectangular rigid plastic
<b>Kitchen to MEV duct type and size</b>		150 & 125 mm diameter rigid plastic & 200 mm rectangular rigid plastic
<b>Wet room to MEV duct type and size</b>		150 & 125 mm diameter rigid plastic & 200 mm rectangular rigid plastic

For more information please visit [airflow.com](http://airflow.com) or email us at [info@airflow.co.uk](mailto:info@airflow.co.uk) or call **01494 560800**

Standard Assessment Procedure – Appendix Q Centralised MEV  
Product Data 04/07/2008

**Results for SAP calculations (at minimum flow rate condition)**

This product has only been tested with rigid ductwork and it is not applicable for SAP Appendix Q if installed with flexible ductwork.

Standard Assessment Procedure – Appendix Q Centralised MEV  
Product Data 01/05/2008

**Table Q1 – Systems with rigid ductwork only**

Exhaust terminal configuration	Fan speed setting	Specific fan power (W/l/s)	Energy Saving Trust Best Practice Performance Compliant
Kitchen + 1 additional wet room	Low	<b>0.55</b>	<b>Yes</b>
Kitchen + 2 additional wet rooms	Medium	<b>0.83</b>	<b>No</b>
Kitchen + 3 additional wet rooms	Medium	<b>0.65</b>	<b>No</b>
Kitchen + 4 additional wet rooms	Medium	<b>0.54</b>	<b>Yes</b>
Kitchen + 5 additional wet rooms	Medium	<b>0.45</b>	<b>Yes</b>

These figures are entered into either:

- (a) In the case of SAP software amended to SAP 2005 version 9.81 allowing direct entry of centralized MEV data, the SAP software, or
- (b) In the case of SAP software amended to SAP 2005 version 9.81 not allowing direct entry of MEV data, the SAP Q MEV Calculation Spreadsheet v9.81 and the results from the spreadsheet into the Special Features part of the SAP 9.81 software, or
- (c) In the case of SAP software to SAP 2005 version 9.80, the SAP Q MEV Calculation Spreadsheet v9.80 and the results from the spreadsheet into the Special Features part of the SAP 9.80 software. They must **NOT** be entered directly into SAP 2005 version 9.80 software

For more information please visit [airflow.com](http://airflow.com) or email us at [info@airflow.co.uk](mailto:info@airflow.co.uk) or call 01494 560800

Standard Assessment Procedure – Appendix Q Centralised MEV  
Product Data 01/05/2008

**Table Q2 – Systems with flexible ductwork only**

Exhaust terminal configuration	Fan speed setting	Specific fan power (W/l/s)	Energy Saving Trust Best Practice Performance Compliant
Kitchen + 1 additional wet room	N/A	N/A	N/A

**Table Q3**

Exhaust terminal configuration	Fan speed setting	Total flow rate (l/s)	Total flow rate – wind condition (l/s)	% reduction of total flow rate
Kitchen + 1 additional wet room	Low	26.6	25.1	6
Kitchen + 2 additional wet rooms	Medium	51.7	51.0	1
Kitchen + 3 additional wet rooms	Medium	52.1	51.7	1
Kitchen + 4 additional wet rooms	Medium	53.4	52.5	2
Kitchen + 5 additional wet rooms	Medium	53.0	52.5	1

**Comments**

Only figures from Table Q1 or Table Q2, not both, should be used with the SAP Q Calculation Spreadsheet for this technology type.

Table Q3 results are only applicable for Approved Document F requirements.

For more information please visit [airflow.com](http://airflow.com) or email us at [info@airflow.co.uk](mailto:info@airflow.co.uk) or call 01494 560800



## Airovent WHV-8 / WHV-8/14

### Why Ventilate?

AIRFLOW fans exceed the requirements of the latest building regulations helping to combat the harmful effects of dampness and condensation and by extracting airborne pollutants such as odours, cooking smells, humid and stale air. The potential hazards to health for occupants and possible damage to the fabric of the building can be largely eliminated.



### WHV-8

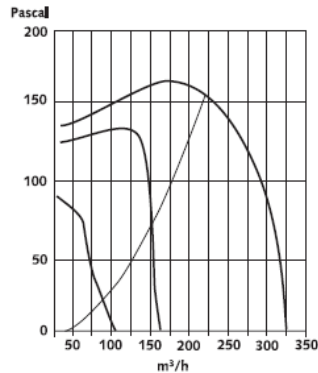

### WHV-8/14

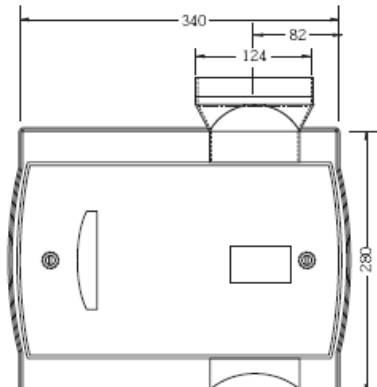
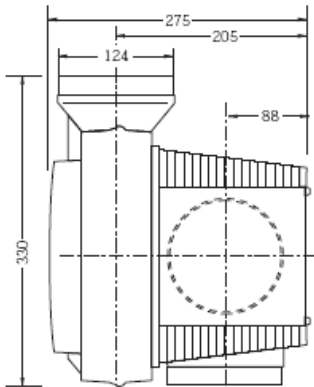
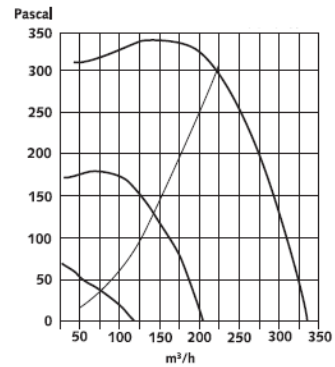

### Unit Dimensions (mm)

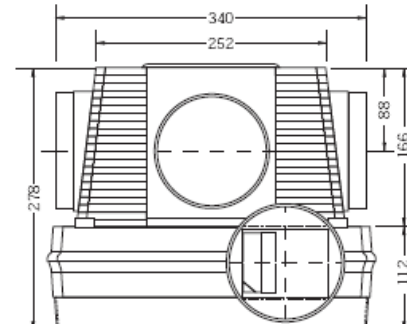

Model	Low air flow (m³/hr)	Medium air flow (m³/hr)	High air flow (m³/hr)	Power (watts)	Supply	Rated current (amps)	Sap-Q Eligible
WHV-8	105	160	325	7/22/41	230V/1PH/50Hz	0.18	✓
WHV-8/14	120	205	335	13/40/73	230V/1PH/50Hz	0.23	

### AIRFLOW VENTILATION SOLUTIONS

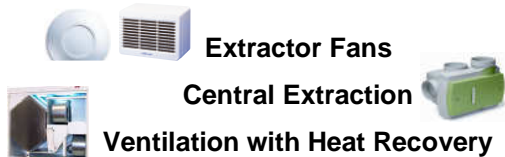

### Accessories

Airese flow control valves to regulate individual room extraction.

For more information please visit [airflow.com](http://airflow.com) or email us at [info@airflow.co.uk](mailto:info@airflow.co.uk) or call 01494 560800

