

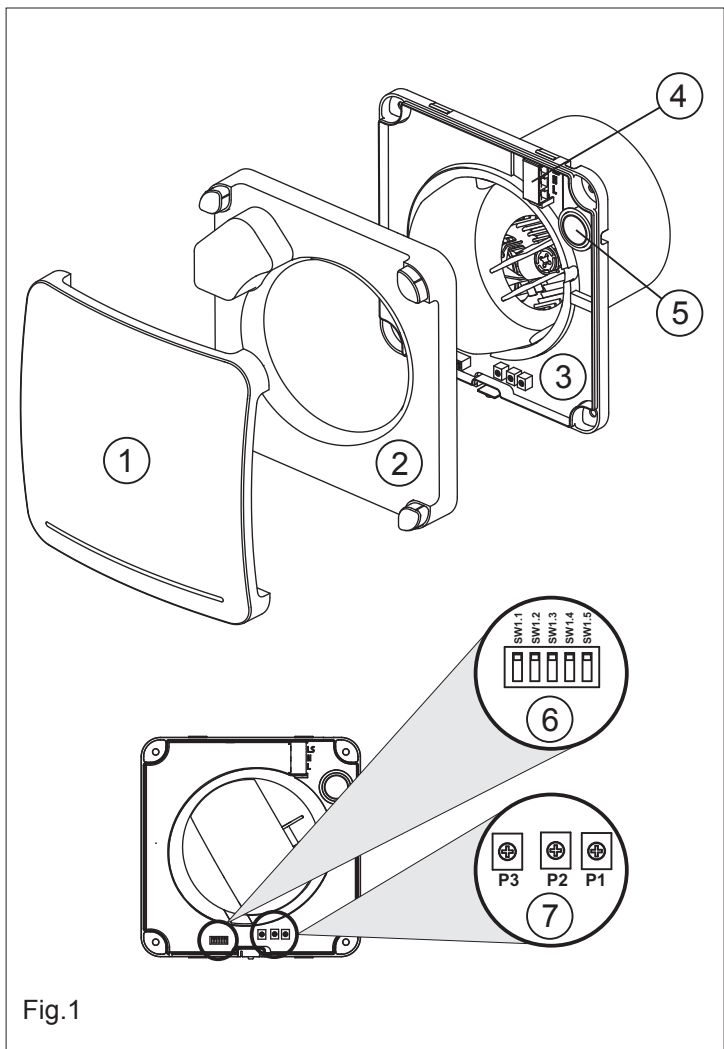

ECO dMEV

Installation Manual





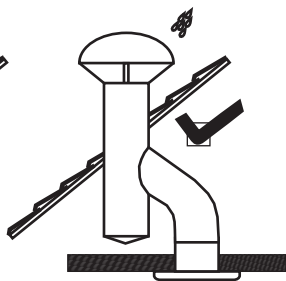
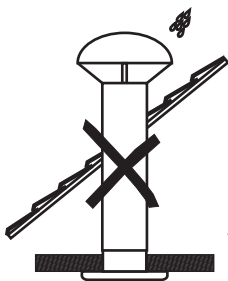
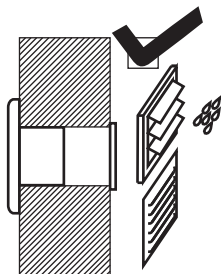
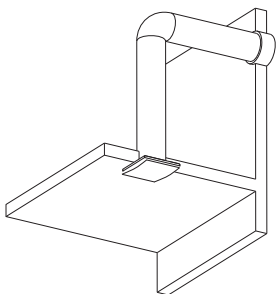
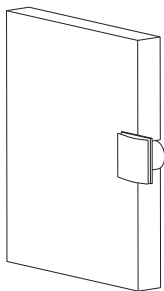
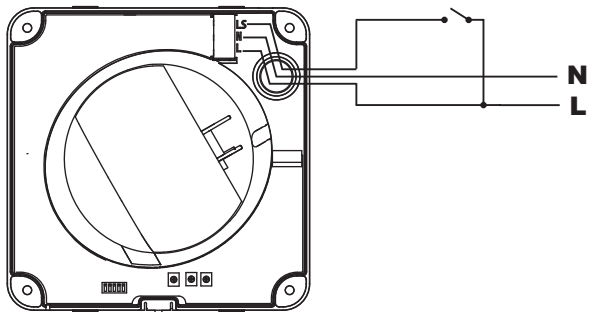
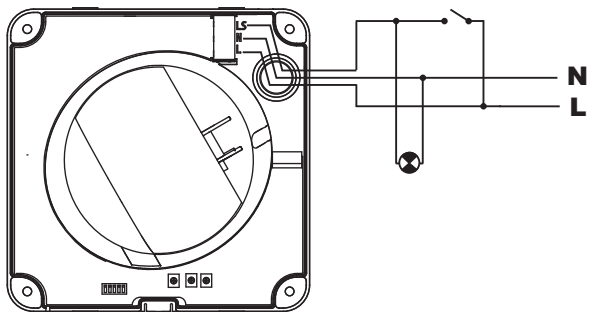
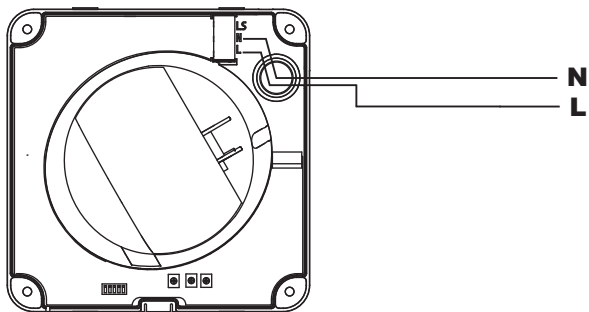
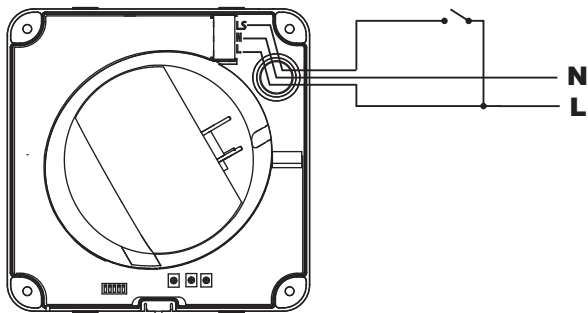
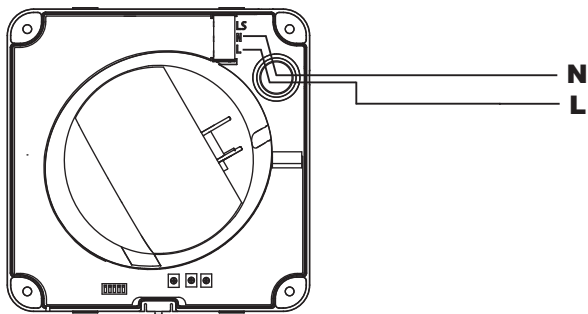
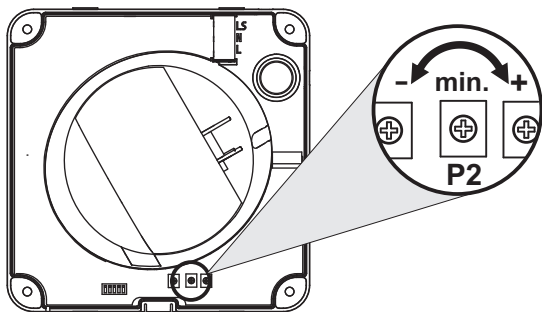

Fig.2





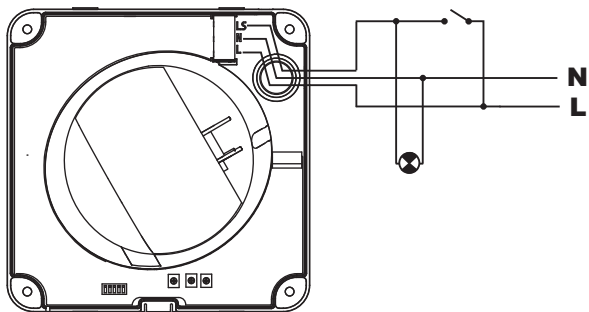

Fig.9

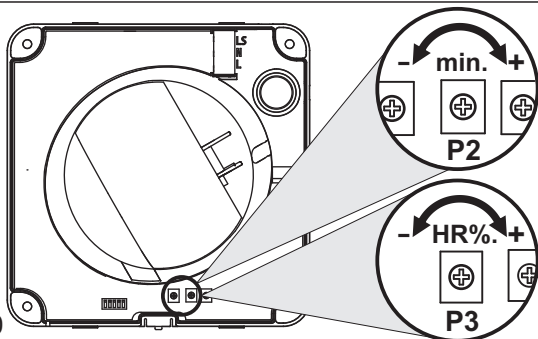

Fig.10

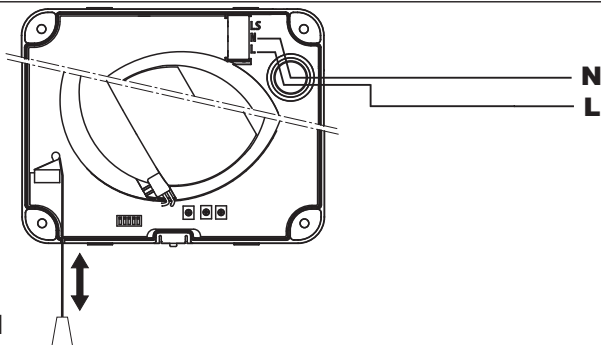

Fig.11

ECO dMEV Centrifugal Extract Fan

The ECO dMEV extract fan range is manufactured to the highest standards of production and quality as laid down by the international Quality Standard ISO 9001. All components have been checked and every one of the final products will have been individually tested at the end of the manufacturing process.

On receipt of the product we recommend that you to check the following:

- 1- That it is the correct model.
- 2- That the details on the rating label are those you require: voltage, frequency...

The installation must be carried out in accordance with Building Regulations and the current I.E.E. wiring regulations (BS7671) or the equivalent standards in force in your country.

This appliance is not intended for use by young children or infirm persons unless they have been adequately supervised by a responsible person to ensure that they can use the appliance safely. Young children should be supervised to ensure that they do not play with the appliance

Installation

IMPORTANT: Before installing and wiring the unit, ensure that the mains supply is disconnected.

Fig. 1:

- 1 : Front grille
- 2: Protection cover
- 3: Support
- 4 : Connection terminals
- 5 : Cable entry
- 6 : Dip switches

The ECO dMEV is suitable for wall or ceiling mounting and can either extract directly to the outside or through a ducted system (see Fig. 2).

Make a Ø105 mm hole in the wall or ceiling.

If the unit is to be installed with ducting, use a standard Ø100mm duct.

Remove the front grille (1) and the protection cover (2).

The unit can be mounted on the wall or ceiling using the 4 rawl plugs and the screws provided.

Ensure that there are no obstructions to the airflow and that the impeller turns freely.

Introduce the mains cable through the cable entry (5) and fix it to the wall.

Connect the electrical wiring as set out below and then mount the protection cover and the front grille.

Electrical connection

The ECO dMEV is an extract fan designed for a single phase supply, with voltage and frequency as indicated on the rating plate of the unit. The units are manufactured with double electrical insulation (Class II) and therefore they do not need an earth connection.

The electrical installation must include a double pole switch with a contact clearance of at least 3 mm.

The electrical cable must enter the ECO dMEV through the cable entry (5).

Once the cable has been introduced proceed using the electrical wiring diagram applicable to the selected model.

Operation

The ECO dMEV is an extract fan designed to operate continuously at low speed and constant volume. The constant flow setting is made with dip-switches placed on the electronic circuit board (Fig. 1);

Constant volume		SW dip switch position	
m ³ /h	l/s	S	T - HT - HTP
15	4		
22	6		
30	9		
36	10		
45	13		

The ECO dMEV may also operate at high speed that is activated by: an external switch live or light switch (**S, T and H versions**); an integral humidity sensor (**H and M versions**); or an internal pull cord switch (**M version**).

ECO dMEV S

The ECO dMEV S can operate in two modes:

1. Continuous operation on trickle setting only (Fig. 3). Once the air volume is set, the fan is connected to the mains and the unit will operate continuously at this air volume.
2. Continuous operation on trickle with the ability to boost on high speed.

The ECO dMEV is connected to an external switch or light switch.

When the switch is pressed, the fan operates on full speed (not constant) until the switch is turned off (light off):

Fig.4- Wiring diagram to boost the fan with the light switch.

Fig.5- Wiring diagram to boost the fan with a separate switch

ECO dMEV T

This model is provided with an adjustable over-run timer. The timer allows the fan to continue to operate for the selected period after the switch has been turned off (fig.5).

Fig.4 shows how to connect the fan with a timer through using the same switch as the lighting circuit to allow the fan to be boosted.

To set the timer, turn the potentiometer "P2" on the printed circuit board as (fig. 6).

- Manufacture setting: 1 minute
- To reduce the "run on" time, turn anticlockwise (min. 1 minute)
- To increase the "run on" time, turn clockwise (max: 30 minutes).

ECO dMEV H

Models provided with an electronic humidity sensor which can be adjusted from 60% to 90 % RH (relative humidity) and with a timer, adjustable between 1 and 30 minutes.

Operation

Case 1: Automatic operation (fig.7)

In automatic operation, the extract fan operates continuously on the trickle setting speed. When the humidity level in the room is higher than the set level the fan will boost to high speed. When the humidity drops below the selected level and after the selected period set on the timer, the fan automatically returns to trickle.

Case 2: Automatic operation as in case 1 with the facility to override the humidity sensor by means of an external switch (fig.8) or light switch (fig.9) when the humidity level in the room is lower than the selected level. In this case, the extract fan continues to operate for the selected period set on the timer after the light switch has been turned off.

ATTENTION: When the humidity rate is above the selected value, the automatic option takes precedence over the manual.

Settings

The settings at manufacture are 60%RH for humidity and 1 minute for timer.

The desired humidity level is selected by means of a potentiometer "P3" positioned on the printed circuit board (fig.10).

- To reduce the humidity setting turn anticlockwise (min.60 %)
- To increase the humidity setting turn clockwise (max. 90 %)

To set the timer, turn the potentiometer "P2" on the printed circuit board (fig.10):

- To reduce the "run on" time, turn anticlockwise (min. 1 minutes)
- To increase the "run on" time, turn clockwise (max: 30 minutes).

Specific recommendations:

- If you change the settings of the extract fan you have to handle the potentiometers in the printed circuit board. These potentiometers are fragile and must be handled with care.
- Do not change the setting of the humidity sensor out of the room where the fan will be installed.
- If the humidity is always above 90% RH, the fan will always run at full speed.
- If the humidity in the room is always less than 60%, the fan will only operate on trickle speed when running in automatic operation.

If the fan never runs on boost:

- The setting of the humidity sensor has been set to maximum. Change the setting
- The level of humidity in the room is below 60% RH

If the fan always runs on boost:

- The setting of the humidity sensor has been set to the minimum. Change the setting

- The level of humidity in the room is above 90% RH

ECO dMEV M

ECO dMEV version similar to H model, fitted with a manual pull cord to operate the boost when the humidity level is below the set point (fig.11).

When switching the pull cord off, the fan will continue to operate on boost for the time set by the timer then will revert to trickle speed, unless the humidity level exceeds the set point.

Maintenance

IMPORTANT: DISCONNECT FROM THE MAINS SUPPLY BEFORE CARRYING OUT ANY MAINTENANCE

The extract fan only requires periodical cleaning using a cloth lightly impregnated with a soft detergent.

After Sales Service

We recommend you not to try to dismantle or remove any other parts than those mentioned as any tampering would automatically cancel the EnviroVent guarantee. If you detect any fault, contact EnviroVent on 01423 810810.

If you have any problems, please call our dedicated Technical Team on 0845 27 27 810.

All EnviroVent products are designed to be recycled when they reach the end of their useful life. To save the environment and to reduce landfill, please call EnviroVent on 01423 810810.



EnviroVent - Delivering innovative and sustainable ventilation solutions worldwide.

EnviroVent Ltd - Envirovent House
Hornbeam Business Park, Harrogate HG2 8PA
Telephone Number: 01423 810810 Fax No: 01423 810910
www.envirovent.com
e-mail: info@envirovent.com

**Please read carefully to ensure simple installation
and a long trouble free life for the user.**

