

SPIR-PRM

Wall Mounted PIR Presence Detector

Overview

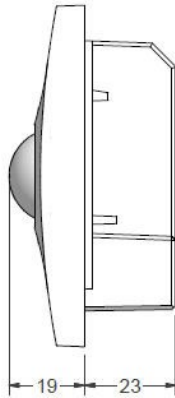
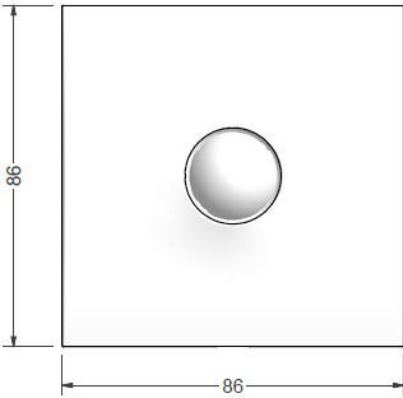

The SPIR-PRM presence detector switches are designed to provide automatic control of lighting, heating or ventilation loads. They detect movement using a PIR sensor and turn the load on. When an area is no longer occupied the load will switch off after an adjustable time out period.

An internal light sensor provides additional energy saving in lighting applications. When an area is occupied lighting is only switched on when the level of natural light is below a preset level.

When the unit is first powered up the PIR sensor will always detect immediately regardless of whether the room is occupied. A selectable power up delay allows the installer to choose whether the load comes on immediately when the unit is powered up or is kept off for a small time (about 40 seconds) to allow the sensor to settle.

Installation & Wiring

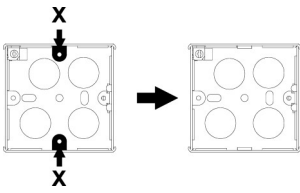

Compatible with all BS4662 dimensions back boxes.

Remove top and bottom lugs if fitted.

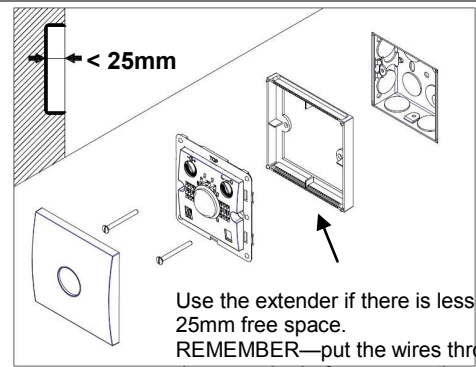
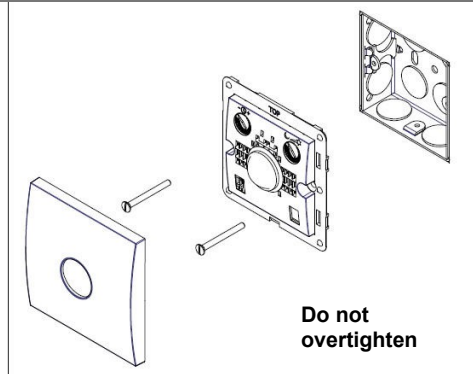

Wire the SPIR-PRM as in the diagram.

To switch from more than one position simply wire two or more units in parallel to achieve two way and intermediate switching.

The detector should be sited so that the occupants of the room fall inside the detection pattern shown below, at a recommended height of 1.2m to 1.5m for wall sensors. Note that the higher the sensor is installed the shorter the detection range will be.

- Avoid direct sunlight entering the sensor.
- Do not site within 1m of forced air heating or ventilation.
- Do not site within 1m of any lighting.
- Do not fix to a vibrating surface.

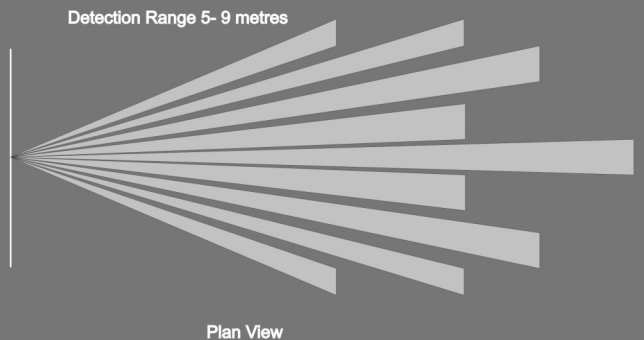
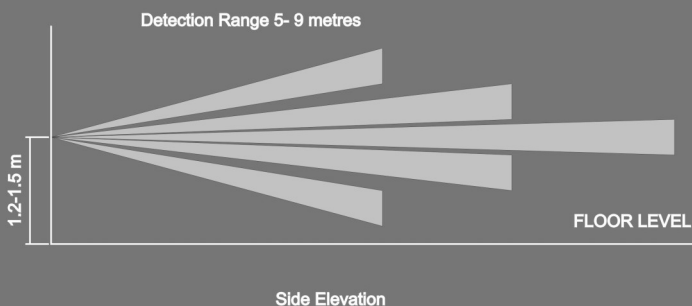
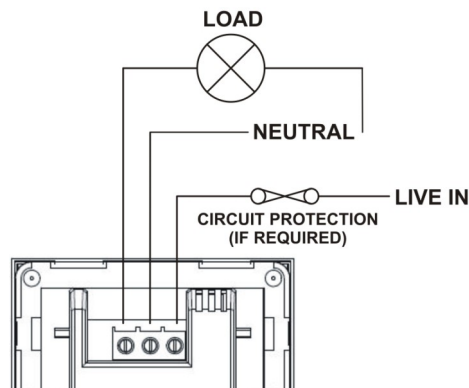

Setup

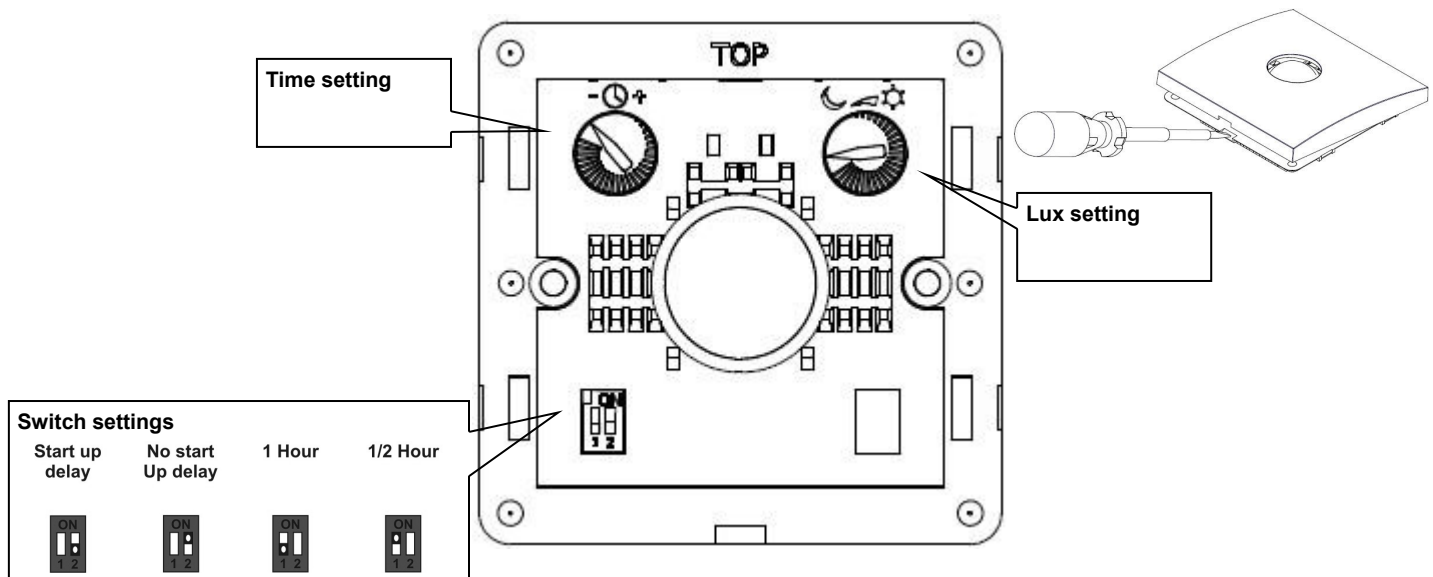

1. Set the LUX level thumbwheel fully clockwise.
2. Set the time to minimum (fully anticlockwise) and set both switches to ON (0-1/2 hour range, no power up delay) according to the diagram.
3. Apply power—the load should come on immediately.
4. Vacate the room or remain very still and wait for the load to switch off (should take no more than 2 minutes).
5. Check that the load switches on when movement is detected.
6. To set the final LUX level wait until the level of natural daylight is just enough that lighting is required. Starting with the LUX thumbwheel fully anti-clockwise. Very slowly turn the thumbwheel clockwise until the lights come on. Note that when the LUX thumbwheel is fully clockwise then the lights will **always** come on with occupancy.
7. Select the time out range using switch 1 according to the diagram. Set the time out period using the thumbwheel, fully clockwise is the maximum (either 1/2 hour or 1 hour depending on the range).
8. If required, select the power up delay using switch 2 (to prevent the load coming on immediately on power up).

Fault Finding

LOAD DOES NOT COME ON

Check to see if the live supply to the circuit is good. Strap across the *L* and *LIVE OUT* terminal to turn the load on.

If the supply and wiring are good, check the LUX level setting. Increase the LUX level setting to allow the controller to turn on at higher ambient natural light level.

LIGHTS DO NOT GO OFF

Ensure that the area is left unoccupied for a greater time period than the time out period set using the switch.

Make sure that the sensor is not adjacent to circulating air, heaters or lamps.

Specification

LOAD

16 Amp resistive load
 10 Amp incandescent lighting
 6 Amp fluorescent lighting
 3 Amp compact fluorescent lighting
 3 Amp low energy lighting
 3 Amp low voltage lighting (switch primary of transformer)
 3 Amp fans and ventilation equipment
 Switch SON lighting loads via a contactor
 Quartz halogen heaters: 2600W max, recommended timing 30 minutes, for lower timing switch via contactor

SUPPLY VOLTAGE 220-240 Volts AC 50 Hz
TIME OUT PERIOD Adjustable 10 seconds to 60 minutes in two ranges
LIGHT LEVEL Optional adjustment by thumbwheel light to dark.
TERMINAL CAPACITY 2.5mm²
MATERIAL Flame retardant ABS
TYPE Class 2
TEMPERATURE -10°C to 35°C
CONFORMITY BS EN60669-2-1 & BS EN55015

Part Numbers

SPIR-PRM Wall mounted PIR presence detector

IMPORTANT NOTICE!

This device should be installed by a qualified electrician in accordance with the latest edition of the IEE wiring regulations.



C.P. Electronics Ltd
 Brent Crescent
 London
 NW10 7XR
 United Kingdom
 Tel: + 44 (0) 333 900 0671
 Fax: + 44 (0) 333 900 0674
 www.cpelectronics.co.uk
 enquiry@cpelectronics.co.uk