



INSTALLATION & MAINTENANCE MANUAL

UNDKIT3WWW / UNDKIT3WCW
UNDKIT3BCWW / UNDKIT3BCCW

GENERAL INSTRUCTIONS

These instructions should be read carefully and retained after installation by the end-user for future reference and maintenance.

These instructions should be used to aid the installation of the following products: UNDKIT3WWW / UNDKIT3WCW / UNDKIT3BCWW / UNDKIT3BCCW

SAFETY

- This product must be installed in accordance with the latest edition of the IEE Wiring Regulations (BS7671) and current Building Regulations. If in any doubt, consult a qualified electrician
- Please isolate mains prior to installation or maintenance
- Check the total load on the circuit (including when this luminaire is fitted) does not exceed the rating of the circuit cable, fuse or circuit breaker
- Please note the IP (Ingress Protection) rating of this luminaire when deciding the location for installation
- This product is Class II double insulated
- This product series is IP20 rated
- **Warning – a minimum of 2 lamps must be attached the driver before energising, failure to follow this instruction will cause damage to the lamp**

INSTALLATION

Note - If this luminaire is being used in conjunction with an external PIR or sensor, please confirm with the manufacturer of the sensors that they are compatible with LED luminaires

Recessed installation

- Provide power to the required point of installation
- Cut a suitable hole in the mounting surface as per the cut-out details (see Fig. 1) ensuring not to infringe with any joists, gas/water pipes or electrical cables

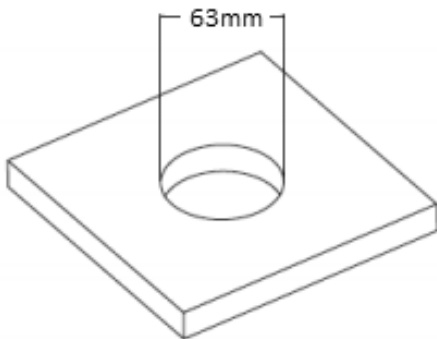

Fig. 1

- Remove the backplate and fit the lamp into the cut-out (see Fig. 2)

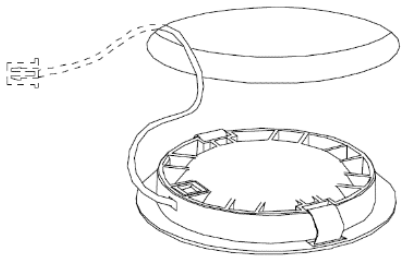

Fig. 2



- Connect the lamp to the 6-way hub (see Fig. 3)

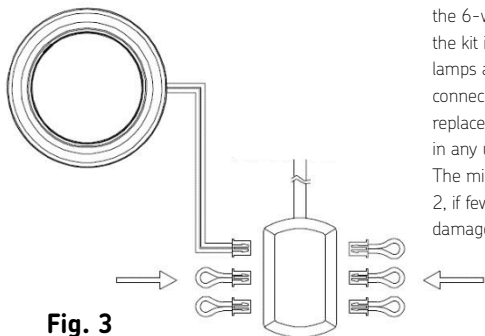

Fig. 3

Note – Before adding or removing lamps from the 6-way hub, please ensure that the power to the kit is switched off. Please note that if more lamps are needed, up to a maximum of 6, a connector should be removed from the hub and replaced by a lamp. Connectors must be inserted in any unused hub terminals for the kit to work. The minimum number of lamps per driver is 2, if fewer are used this will cause irreparable damage to the lamp.

- Connect the pre-wired 6-way hub to the secondary side of the driver ensuring that correct polarity is observed: Positive – (red); Negative – (black)
- Connect the driver to the mains supply ensuring that correct polarity is observed: L – Live (brown), N – Neutral (blue)
- Switch on and check for correct operation

Surface Mounting

- Provide power to the required point of installation
- Using the mounting bracket as a template, mark the location for, and drill the fixing holes ensuring not to infringe with any gas/water pipes or electrical cables
- Fix the base to a suitable solid surface using the screws provided. Please ensure that the lamp cable is routed through the slot in the backplate (see Fig. 4)

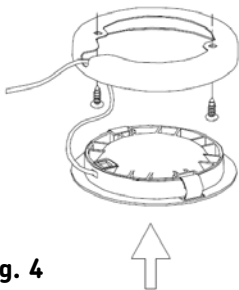
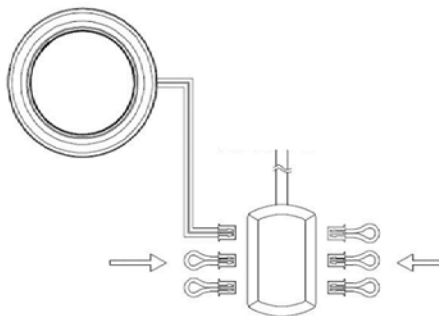

Fig. 4

- Connect the lamp to the 6-way hub (see Fig. 5)

Fig. 5



Note – Before adding or removing lamps from the 6-way hub, please ensure the power to the kit is switched off. Please note that if more lamps are needed, up to a maximum of 6, a connector should be removed from the hub and replaced by a lamp. Connectors must be inserted in any unused hub terminals for the kit to work. The minimum number of lamps per driver is 2, if fewer are used, this will cause irreparable damage to the lamp.

- Connect the prewired 6-way hub to the secondary side of the driver ensuring correct polarity is observed: Positive – (red); Negative – (black)
- Connect the driver to the mains supply ensuring correct polarity is observed: L – Live (brown), N – Neutral (blue)
- Switch on and check for correct operation

ADDITIONAL ACCESSORIES

The kit can be expanded by adding extra lamps, to a maximum of 6 per driver.

PART CODE	DESCRIPTION
UNDK3WWW	3000K White
UNDK3WCW	4000K White
UNDK3BCWW	3000K Brushed Chrome
UNDK3BCCW	4000K Brushed Chrome

WARNING

This luminaire must be disconnected from the circuit if subjected to any high voltage or insulation resistance testing. Irreparable damage will occur if this instruction is not followed.

GENERAL

The LED lamps fitted in this product are non-replaceable. The product should be recycled in the correct manner when it reaches the end of its life. Check local authorities for where facilities exist.

Clean with a soft dry cloth only, do not use aggressive cleaning products or solvents which may damage the product.

This luminaire is dimmable with a trailing-edge dimmer only.

WARRANTY

This product has a warranty of 3 years from the date of purchase. Failure to install this product in accordance with the current edition of the IEE Wiring Regulations (BS7671), improper use, or removal of the batch code will invalidate the warranty. If this product should fail within its warranty period, it should be returned to the place of purchase for a free of charge replacement. ML Accessories does not accept responsibility for any installation costs associated with the replacement product. Your statutory rights are not affected. ML Accessories reserve the right to alter product specification without prior notice.



ML
ACCESSORIES LTD



ML Accessories Limited LU5 4LT
www.mlaccessories.co.uk